

FOR 1/4-20 MACHINE SCREWS USE No.7 DRILL & TAP
 FOR No.14 WOOD SCREWS USE 5/32" DRILL
 FOUR (4) HOLES IN SOFFIT FOR SOFFIT PLATE

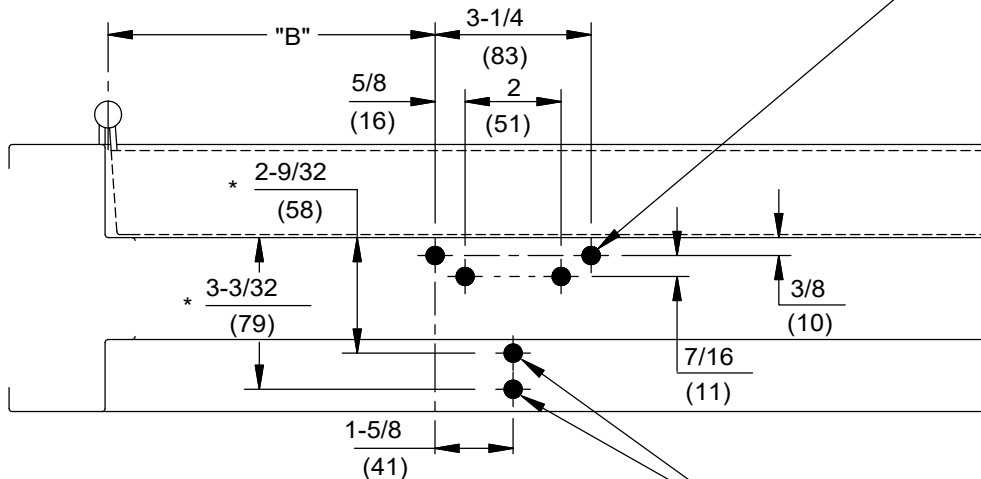

*IMPORTANT: CHOOSE APPROPRIATE FIFTH HOLE LOCATION FOR SPACER BLOCK, IN ACCORDANCE WITH FRAME WIDTH. ONE (1) HOLE IN FRAME FOR BLOCK

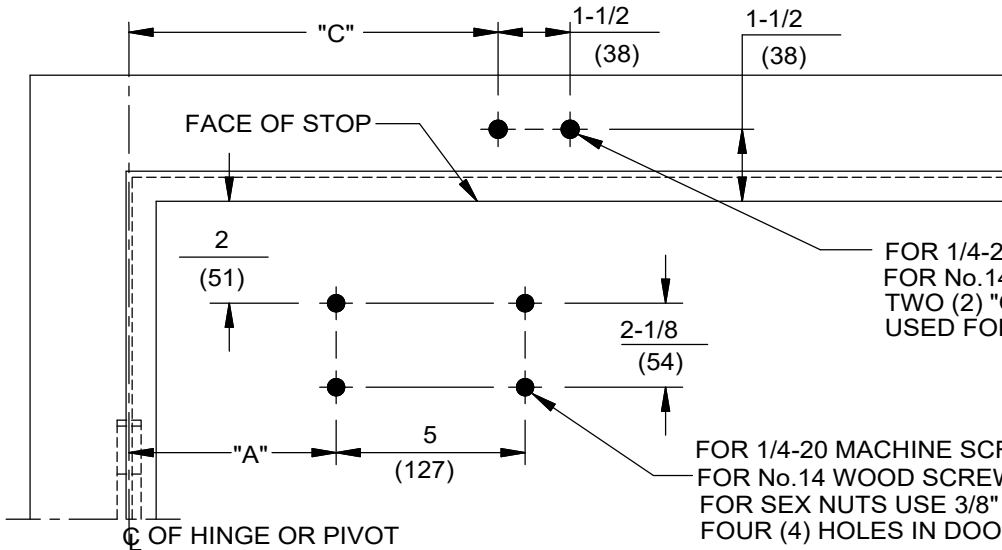

FOR 1/4-20 MACHINE SCREWS USE No.7 DRILL & TAP
 FOR No.14 WOOD SCREWS USE 5/32" DRILL
 TWO (2) "OPTIONAL" HOLES IN FRAME USED FOR OPTIONAL (NFHD) BRACKET

FOR 1/4-20 MACHINE SCREWS USE No.7 (0.201") DRILL & TAP
 FOR No.14 WOOD SCREWS USE 5/32" DRILL
 FOR SEX NUTS USE 3/8" DRILL
 FOUR (4) HOLES IN DOOR FOR CLOSER

ANGLE OF OPENING HOLD OPEN	DIM. "A" CLOSER	DIM. "B" SOFFIT PLATE	DIM. "C" (NFHD) OPTIONAL BRACKET
TO 180°	3-1/2	4-3/4	5-5/8
H.O. 130°	(89)	(121)	(143)

NOTES:

1. DO NOT SCALE DRAWING.
2. DIMENSIONS ARE IN INCHES/(MM).
3. LEFT HAND DOOR SHOWN.
4. CAUTION: SEX NUTS ARE REQUIRED FOR ATTACHMENT OF COMPONENTS TO UNREINFORCED DOORS AND TO WOOD OR PLASTIC FACED COMPOSITE TYPE FIRE DOORS, UNLESS AN ALTERNATIVE METHOD IS IDENTIFIED IN THE INDIVIDUAL DOOR
5. FOR FRAME WIDTHS 4-1/2" AND LESS USE OPTIONAL (NFHD) BRACKET.
6. MINIMUM DOOR WIDTH 26".
7. TEMPLATING BASED ON MARKAR 300 CONTINUOUS HINGES.

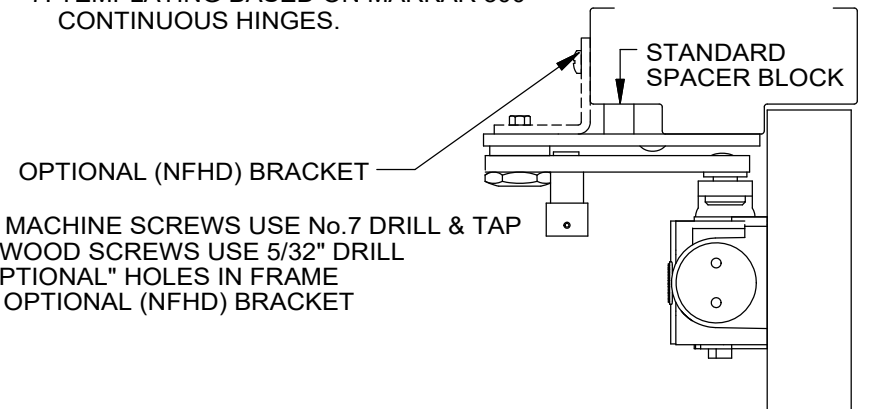

DOOR CLOSER MODELS: 8900 (SPA, SPAT, SPAK) x SK-2046
 PARALLEL ARM INSTALLATION (PUSH SIDE MOUNT) WITH STANDARD SPACER BLOCK
 FOR MARKAR 300 CONTINUOUS HINGE
 OPTIONAL NFHD BRACKET AND BSHD BLADE STOP SPACER BLOCK